

Saer IR Series

SAER
ELETTROPOMPE

- End suction close coupled centrifugal pump
- Cast iron pump body
- Moderate pressure, high volume pump
- Ideal for farm wash down pumps and machinery wash down bays
- Suitable for water supply, factory main water supply or industrial circulation
- Flanged inlet and outlet
- Requires flange kit
- Made in Italy

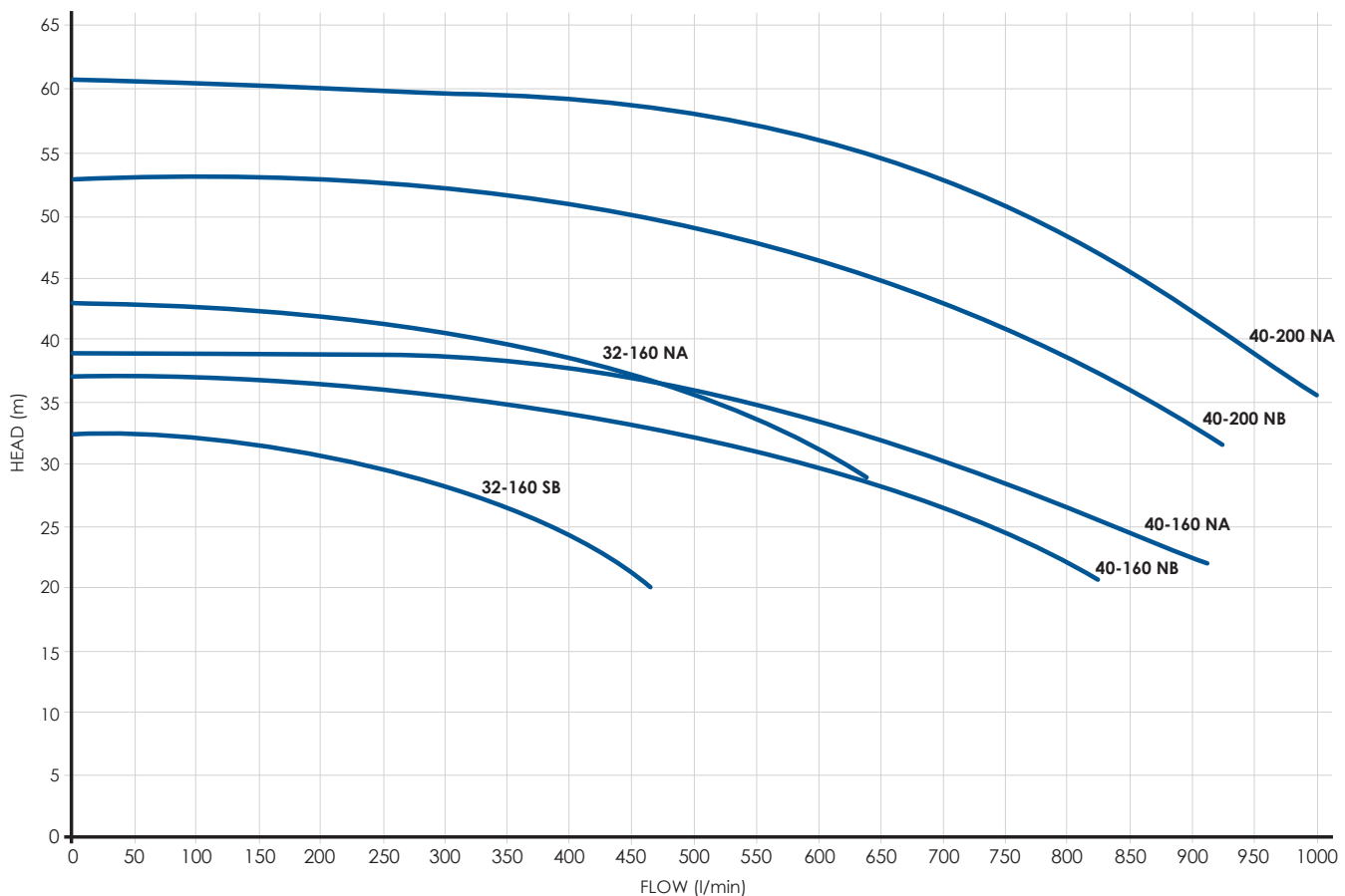
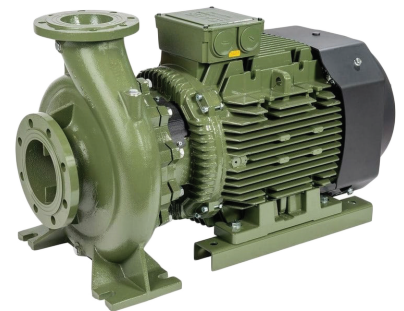

PERFORMANCE GUIDE

Code	Max Head (m)	Max Flow (l/min)	Max Pressure (PSI)	Inlet (mm)	Outlet (mm)
PUSAERIR32-160SBT	32.5	467	46	50	32
PUSAERIR32-160NAT	43	633	41	50	32
PUSAERIR40-160NB/BT	36.5	583	51	65	40
PUSAERIR40-160NAT	39	917	55	65	40
PUSAERIR40-200NBT	53	917	75	65	40
PUSAERIR40-200NAT	61	1000	86	65	40



Electric Motors | Drives | Pumps | Bearings | Power Transmission | Workshop Services
06 354 3651 | sales@soco.co.nz | www.soco.co.nz | 471 Tremain Avenue, Palmerston North

Saer IR Series

SAER[®]
ELETTROPOMPE

- End suction close coupled centrifugal pump
- Cast iron pump body
- Moderate pressure, high volume pump
- Ideal for farm wash down pumps and machinery wash down bays
- Suitable for water supply, factory main water supply or industrial circulation
- Flanged inlet and outlet
- Requires flange kit
- Made in Italy

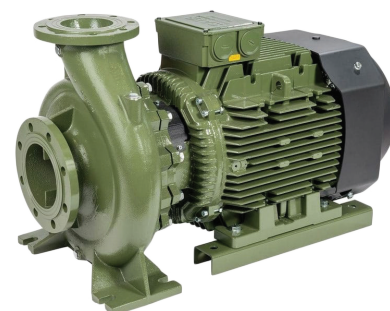

ELECTRICAL DATA

Code	Current Type	kW	Hp	Amps	RPM/min	Insulation Class	Voltage (V)	Frequency (Hz)
PUSAERIR32-160SBT	Three	3	4		2900	F	230/400	50
PUSAERIR32-160NAT	Three	5.5	7.5	10.7	2900	F	400	50
PUSAERIR40-160NB/BT	Three	4	5.5	14/8.1	2900	F	230/400	50
PUSAERIR40-160NAT	Three	5.5	7.5	10.3	2900	F	230/400	50
PUSAERIR40-200NBT	Three	7.5	10	15.5	2900	F	400	50
PUSAERIR40-200NAT	Three	11	15	21.2	2900	F	400	50

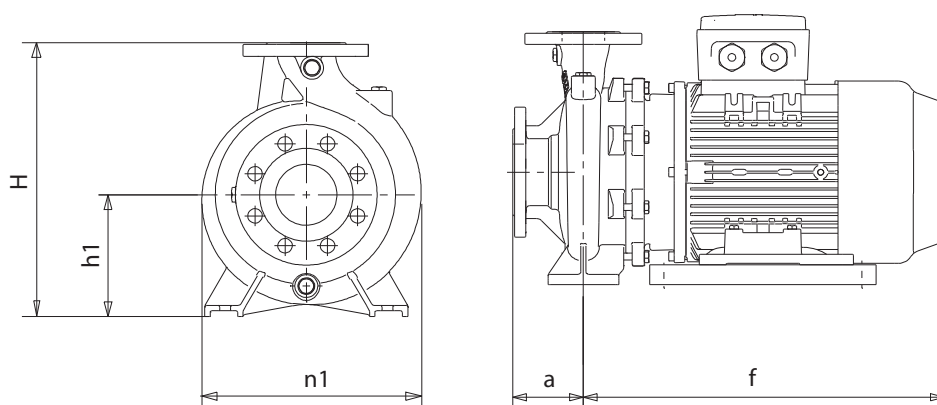

DIMENSIONS + WEIGHTS

Code	H (mm)	h1 (mm)	n1 (mm)	a (mm)	f (mm)	Weight (kg)
PUSAERIR32-160SBT	292	132	240	80	459	42
PUSAERIR32-160NAT	292	132	240	80	450	53
PUSAERIR40-160NB/BT	292	132	240	80	426	55
PUSAERIR40-160NAT	292	132	240	80	450	59
PUSAERIR40-200NBT	340	160	265	100	504	83
PUSAERIR40-200NAT	340	160	265	100	504	85

